

# Table of Contents

<b>1. Introduction</b>	<b>6</b>
1.1. Features.....	7
1.2. Monitor Specifications.....	8
1.3. Box Content.....	9
1.4. About the LCD Stand Pin.....	10
1.5. Views of the Monitor.....	11
<b>2. Getting Connected</b>	<b>13</b>
2.1. Connecting the Monitor to Your Computer.....	14
2.2. Connecting Headphones or Speakers.....	15
2.3. Connecting USB Devices.....	15
2.4. Ergonomic Adjustments.....	16
2.4.1. Raise and Lower Monitor Screen.....	16
2.4.2. Screen Tilt.....	16
2.4.3. Swivel.....	16
2.5. Installing an Alternative Stand or Attachment.....	17
<b>3. Monitor Operation</b>	<b>18</b>
3.1. About Zoom Modes and Aspect Ratio.....	19
3.2. Using the Picture-in-Picture (PiP) Function.....	20
3.2.1. Turning PiP On/Off.....	20
3.2.2. Adjusting the Position of the PiP.....	20
3.2.3. Modifying the PiP Size.....	20
3.2.4. Switching Audio Output to Speakers.....	21
3.2.5. Switching Input Source Displayed on the PiP.....	21
<b>4. Settings and Adjustments</b>	<b>22</b>
4.1. Settings and Adjustments (Basic Operation).....	23
4.2. Advanced Settings.....	24
4.2.1. PiP Settings.....	24
4.2.2. DVI/VGA Settings.....	25
4.2.3. HDMI Video Settings.....	26
4.2.4. Other Settings.....	28
<b>5. Troubleshooting</b>	<b>29</b>
<b>6. Contacting Customer Support</b>	<b>31</b>
Before You Contact Technical Support.....	31
LaCie Customer Support Contacts.....	32
<b>7. Warranty Information</b>	<b>33</b>

### Copyrights

Copyright © 2011 LaCie. All rights reserved. No part of this publication may be reproduced, stored in a retrieval system, or transmitted in any form or by any means, electronic, mechanical, photocopying, recording or otherwise, without the prior written consent of LaCie.

### Changes

The material in this document is for information only and subject to change without notice. While reasonable efforts have been made in the preparation of this document to assure its accuracy, LaCie assumes no liability resulting from errors or omissions in this document, or from the use of the information contained herein. LaCie reserves the right to make changes or revisions in the product design or the product manual without reservation and without obligation to notify any person of such revisions and changes.

### FCC Declaration of Conformity:



NOTE: This equipment has been tested and found to comply with the limits for a Class B digital device, pursuant to Part 15 of the FCC Rules. These limits are designed to provide reasonable protection against harmful interference in a residential installation. This equipment generates, uses and can radiate radio frequency energy and, if not installed and used in accordance with the instructions, may cause harmful interference to radio communications. However, there is no guarantee that interference will not occur in a particular installation. If this equipment does cause harmful interference to radio or television reception, which can be determined by turning the equipment off and on, the user is encouraged to try

and correct the interference by one or more of the following measures:

- ◆ Reorient or relocate the receiving antenna.
- ◆ Increase the separation between the equipment and receiver.
- ◆ Connect the equipment into an outlet on a circuit different from that to which the receiver is connected.
- ◆ Consult the dealer or an experienced radio/TV technician for help.
- ◆ Use only shielded cables to connect I/O devices to this equipment.

Use the attached specified cables with the LaCie 324 monitor so as not to interfere with radio and television reception.

1. The power supply cord you use must have been approved by and comply with the safety standards of U.S.A. and meet the following condition.

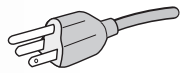
Power supply chord	Non shield type, 3-conductor
Length	2.0 m
Plug shape	 (USA)

2. Please use the supplied shielded video signal cable. Use of other cables and adapters may cause interference with radio and television reception.

### U.S. Responsible Party:

LaCie, LTD

### Address:

22985 NW Evergreen Pkwy.  
Hillsboro, OR 97124

### Tel. No.:

(503) 844-4503

### CE Manufacturer's Declaration for CE Certification

We, LaCie, solemnly declare that this product conforms to the following European directives: 2004/108/EC (EMC), and 2006/95/EC (Safety)

LaCie S.A.

33 Bld du Général Martial Valin  
75015 Paris

France

**CAUTION:** Modifications not authorized by the manufacturer may void the user's authority to operate this device.

**CAUTION:** A shielded-type power cord is required in order to meet FCC emission limits and also to prevent interference to the nearby radio and television reception. It is essential that only the supplied power cord be used.

## Safety Precautions and Maintenance

- ◆ DO NOT OPEN THE MONITOR. There are no user serviceable parts inside and opening or removing covers may expose you to dangerous shock hazards or other risks. Refer all servicing to qualified service personnel.
- ◆ Do not spill any liquids into the cabinet or use your monitor near water.
- ◆ Do not insert objects of any kind into the cabinet slots, as they may touch dangerous voltage points, which can be harmful or fatal or may cause electric shock, fire or equipment failure.
- ◆ Do not place any heavy objects on the power cord. Damage to the cord may cause shock or fire.
- ◆ Do not place this product on a sloping or unstable surface, as the monitor may fall, causing serious damage.
- ◆ Do not place any objects onto the monitor and do not use the monitor outdoors.
- ◆ The inside of the fluorescent tube located within the LCD monitor contains mercury. Please follow the bylaws or rules of your municipality to dispose of the tube properly.
- ◆ Do not bend power cord.
- ◆ Do not use monitor in high temperatures, humid, dusty, or oily areas.
- ◆ Do not cover vent on monitor.  
Immediately unplug your monitor from the outlet and refer servicing to qualified personnel under the following conditions:
- ◆ When the power supply cord or plug is damaged.
- ◆ If liquid has been spilled, or objects have fallen into the monitor.
- ◆ If the monitor has been exposed to rain or water.
- ◆ If the monitor has been dropped or the cabinet damaged.
- ◆ If the monitor does not operate normally by following operating instructions.
- ◆ If glass is broken, handle with care.
- ◆ If monitor or glass is broken, do not come in contact with the liquid crystal and handle with care.
- ◆ Allow adequate ventilation around the monitor so that heat can properly dissipate. Do not block ventilated openings or place the monitor near a radiator or other heat sources. Do not put anything on top of monitor.
- ◆ The power cable connector is the primary means of detaching the system from the power supply. The monitor should be installed close to a power outlet which is easily accessible.
- ◆ Handle with care when transporting. Save packaging for transporting.
- ◆ Image Persistence: Please be aware that LCD Technology may experience a phenomenon known as Image Persistence.
- ◆ Image Persistence occurs when a residual or “ghost” image of a previous image remains visible on the screen. Unlike CRT monitors, LCD monitors’ image persistence is not permanent, but constant images being displayed for a long period of time should be avoided. To alleviate image persistence, turn off the monitor for as long as the previous image was displayed. For example, if an image was on the monitor for one hour, the monitor should be turned off for one hour to erase the image.
- ◆ When operating the LaCie 324 LCD Monitor with a 220-240V AC power source in Europe, use the power cord provided with the monitor.
- ◆ In the UK, a BS approved power cord with a moulded plug has a Black (five Amps) fuse installed for use with this equipment.
- ◆ If a power cord is not supplied with this equipment please contact your supplier.
- ◆ When operating the LaCie 324 LCD Monitor with a 220-240V AC power source in Australia, use the power cord provided with the monitor. If a power cord is not supplied with this equipment please contact your supplier.
- ◆ For all other cases, use a power cord that matches the AC voltage of the power outlet and has been approved by and complies with the safety standard of your particular country.

## Health and Ergonomic Precautions

Correct placement and adjustment of the monitor can reduce eye, shoulder and neck fatigue. Check the following when you position the monitor:

- ◆ For optimum performance, allow 20 minutes for warm-up.
- ◆ Adjust the monitor height so that the top of the screen is at or slightly below eye level. Your eyes should look slightly downward when viewing the middle of the screen.
- ◆ Position your monitor no closer than 40 cm and no further away than 70 cm from your eyes. The optimal distance is 50 cm.

- ◆ Rest your eyes periodically by focusing on an object at least 20 feet away. Blink often.
- ◆ Position the monitor at a 90° angle to windows and other light sources to minimize glare and reflections. Adjust the monitor tilt so that ceiling lights do not reflect on your screen.
- ◆ If reflected light makes it hard for you to see your screen, use an anti-glare filter.
- ◆ Clean the LCD monitor surface with a lint-free, non-abrasive cloth. Avoid using any cleaning solution or glass cleaner!

- ◆ Adjust the monitor's brightness and contrast controls to enhance readability.
- ◆ Use a document holder placed close to the screen.
- ◆ Position whatever you are looking at most of the time (the screen or reference material) directly in front of you to minimize turning your head while you are typing.
- ◆ Avoid displaying fixed patterns on the monitor for long periods of time to avoid image persistence (after-image effects).



To maximize ergonomics benefits, we recommend the following:

- ◆ Adjust the brightness until the background raster disappears.
- ◆ Do not position the contrast control to its maximum setting.
- ◆ Use the preset size and position controls with standard signals.

- ◆ Use the preset color setting.
- ◆ Use non-interlaced signals with a vertical refresh rate between 60-75 Hz.
- ◆ Do not use primary color blue on a dark background, as it is difficult to see and may produce eye fatigue to insufficient contrast.



### Within the European Union

EU-wide legislation, as implemented in each Member State, requires that waste electrical and electronic products carrying the mark (above) must be disposed of separately from normal household waste. This includes monitors and electrical accessories, such as signal cables or power

cords. When you need to dispose of your LaCie display products, please follow the guidance of your local authority, or ask the shop where you purchased the product, or if applicable, follow any agreements made between yourself and LaCie.

The mark on electrical and electronic products only applies to the current Eu-

ropean Union Member States.

### Outside the European Union

If you wish to dispose of used electrical and electronic products outside the European Union, please contact your local authority so as to comply with the correct disposal method.

## Manufacturer's Recycling and Energy Information

LaCie is strongly committed to environmental protection and sees recycling as one of the company's top priorities in trying to minimize the burden placed on the environment. We are engaged in developing environmentally friendly products, and always strive to help define and comply with the latest independent standards from agencies.

Recycling programs information:

Sweden - <http://www.el-retur.se>

Germany - <http://www.recyclingpartner.de/>

Holland - <http://www.mirec.nl/>

### Energy saving:

This monitor features an advanced energy saving capability. When a VESA Display Power Management Signaling (DPMS) Standard signal is sent to the monitor, the Energy Saving mode is activated. The monitor enters a single Energy Saving mode.

Mode	Power Consumption	LED color
Normal operation	140W	Blue
Energy saving mode	Less than 2W	Orange
Off	Less than 1W	N/A



# 1. Introduction

Thank you for purchasing a LaCie 324 LCD Monitor.

Designed for creative professionals, this LCD monitor features a 24-inch wide-gamut LCD panel, 10-bit gamma correction and full HD support for the best video experience available. With DCDi® by Faroudja video enhancement technologies and full hardware calibration support, this monitor is ideal for work on both still and moving images. The optional LaCie blue eye colorimeter and blue eye pro software are the ideal tools to tune your monitor for the most realistic rendering of your images.

The LaCie 324 also includes a convenient audio jack to connect your headphones or speakers and three powered USB 2.0 ports for all your USB devices.

## Quick Links

Click to jump to a section:

- ◆ Getting Connected
- ◆ Monitor Operation
- ◆ Troubleshooting



## 1.1. Features

**Wide-Gamut S-PVA panel technology** offers an industry-leading 92% NTSC Gamut that allows the LaCie 324 monitor to display a large range of vibrant colors previously unattainable by LCD monitors. This technology also offers an excellent balance between contrast (1000:1) and brightness (400 cd/m<sup>2</sup> typ.) and an expansive viewing angle of 178°.

**10-bit Gamma Correction** ensures a smooth rendering of color gradients such as those commonly found in photography and digital art.

### Hardware Calibration

The LaCie 324 can be hardware-calibrated with appropriate calibration tools. We recommend using LaCie blue eye pro, optimized for LaCie monitors.

### Full High Definition Support

The monitor supports 1080p, 1080i, 720p and 720i resolutions and features two HDCP-compatible HDMI input ports to connect a variety of full HD sources for the best video experience available.

### DCDi® by Faroudja

DCDi® by Faroudja is a suite of video enhancement technologies that produce exceptional image quality:

- ◆ Reduces “jagged edges” (typical with interlaced video signals)
- ◆ TrueLife™ improved detail rendering
- ◆ Adaptive contrast
- ◆ Motion-adaptive Noise Reduction

**Supports up to 4 video sources** with simultaneous viewing of 2 sources through the **Picture-in-Picture (PiP)** function.

**Large 24-inch (61 cm) diagonal size and wide 16:10 format** enhances productivity by reducing the need for scrolling through documents and switching windows. View full 1:1 scale display of two full pages with additional space for application palettes and tool bars.

**High 1920x1200 resolution** is ideal for high resolution graphics applications.

**Convenient audio line out** serves as headphone or speaker connector.

**Convenient USB hub** located on the rear left side of front panel for connection of USB devices such as LaCie external hard drives or the LaCie blue eye pro calibrator.

**Ergonomic stand** enables height, swivel, and tilt adjustments.

### VESA 100 mounting interface

The monitor can be attached to any VESA 100 compatible attachment.

---

## 1.2. Monitor Specifications

Technology	Wide-Gamut S-PVA
Display Diagonal	24 inches (61 cm)
Active Display Area	518.4 (H) x 324 (V) mm
Resolution	Some systems may not support all modes listed. <b>Primary mode</b> : 1920 x 1200 at 60 Hz – LaCie recommends this resolution for optimal display performance. <b>Secondary modes</b> : 720x400@70Hz, 823x624@75Hz, 1280x960@60Hz, 640x480@60 Hz/67Hz/72Hz/75Hz, 800x600@56Hz/60Hz/72Hz/75Hz, 1600x1200@60Hz, 1024x768@60Hz/70Hz/75Hz, 1280x1024@60Hz/75Hz, 1440x900@60Hz, 720x480, 1280x720, 1920x540, 1920x1080@60Hz, 640x400@56Hz, 848x480@60Hz, 1280x720@60Hz, 1280x768@60Hz, 1360x768@60Hz
Pixel pitch	0.270 mm, 89 PPI
Gamut	92% NTSC
Color depth	16,777,216
Gamma correction	10 bit
Luminance	400 cd/m <sup>2</sup> (typical)
Contrast ratio	1000:1 (typical)
Response time	Rise time + Fall time : 16ms (typical) 8ms G to G
Viewing angles	Left/Right ±178°, Up/Down ±178°
Connections	Mini D-Sub, DVI-D, 2xHDMI
Power consumption	140W typical, <2W in power save mode
Weight	10.8 kg, 7.9 kg without stand, 13.4 kg with packaging and accessories
Ergonomy	Up / Down 29° to -5°, Left / Right 350°, Height : 70 mm
Operating Conditions	Temp 5° to 35°, Humidity 10% to 90%, Altitude 0 to 10,000 ft.
Storing Conditions	Temp 20° to 60°, Humidity 10% to 90%, Altitude 0 to 40,000 ft.
Certifications	CE, FCC-B, EnergyStar, GOST-R, CSA, ISO 13406-2, PSB, WEEE, ROHS

\*Interpolated Resolutions: When resolutions are shown that are lower than the pixel count of the LCD module, text may appear different. This is normal and necessary for all current flat panel technologies when displaying non-native resolutions full screen. In flat panel technologies, each dot on the screen is actually one pixel, so to expand resolutions to full screen, an interpolation of the resolution must be done.



### 1.3. Box Content

Your box contains the LaCie 324 LCD Monitor and items 2 -9, listed below:

- ① LaCie 324 LCD Monitor
- ② DVI-D cable
- ③ HDMI-HDMI cable
- ④ Audio jack cable
- ⑤ AC power cable
- ⑥ USB host cable
- ⑦ Cable management accessory
- ⑧ CD-ROM with User Manual and monitor ICC profiles
- ⑨ Quick Install Guide



**IMPORTANT INFO:** Please keep the product box and packing materials, including the LCD stand pin, and store in a safe area in case you need to safely transport your product in the future. In the event that the monitor should need to be repaired or serviced, it must be returned in its original packaging.

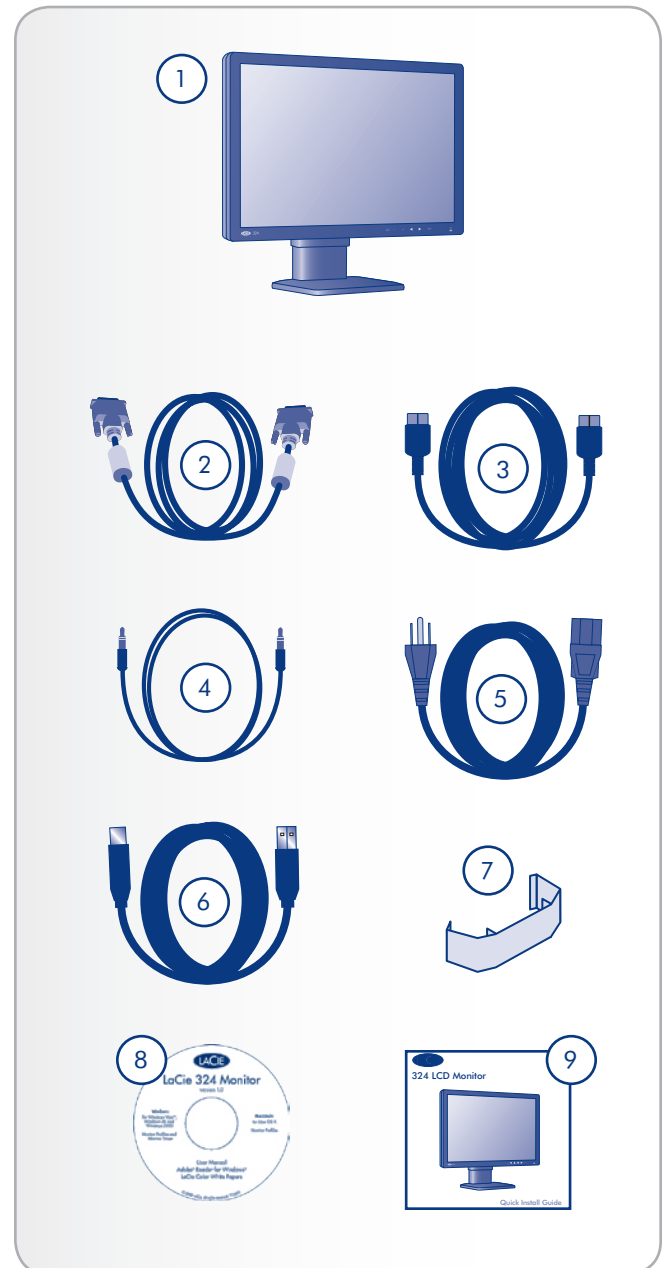

## 1.4. About the LCD Stand Pin

The monitor's LCD stand is secured during transport using a pin near the base of the stand. Please follow the procedure below to remove it.

1. Take the monitor out of the box and remove cushioning material. Do not remove the pin yet.
2. Place the monitor on a desk or other horizontal surface. **Do not remove the pin yet.**



**CAUTION:** If the pin is removed while the product is on its side, the stand may extend forcefully, causing it to hit the body of the handler or to fall, resulting in personal injury or damage to the product.

3. Peel off the seal and remove the pin.

Be sure to keep the pin in an easily accessible location, as it may be required in the future when repacking this product for transport.

When transporting the monitor in the future, adjust the LCD to its lowest position and insert the pin into the LCD stand base to lock it in place. The monitor can then be inserted back into the cushioning material and into its box.

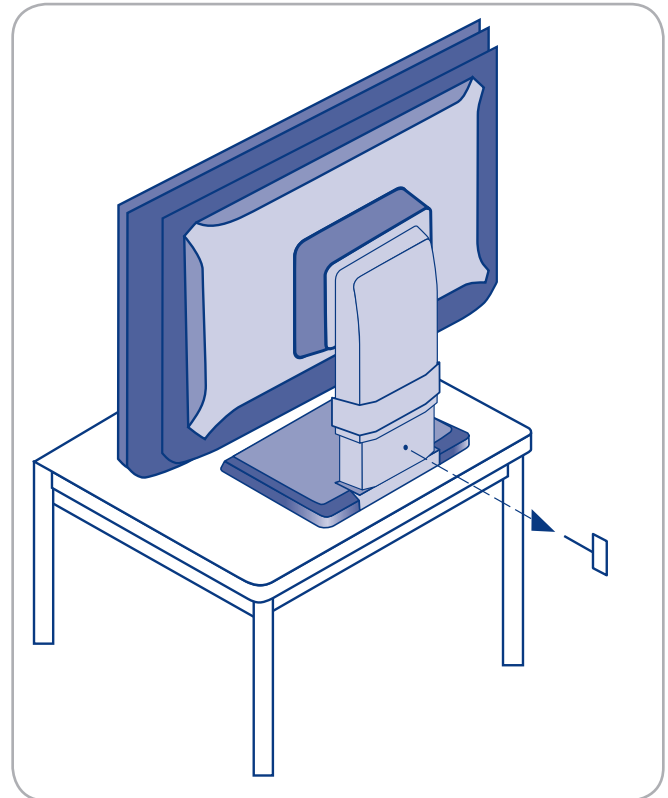

## 1.5. Views of the Monitor

### Front View

Refer to the diagram below for the names and functions of each component of the monitor.

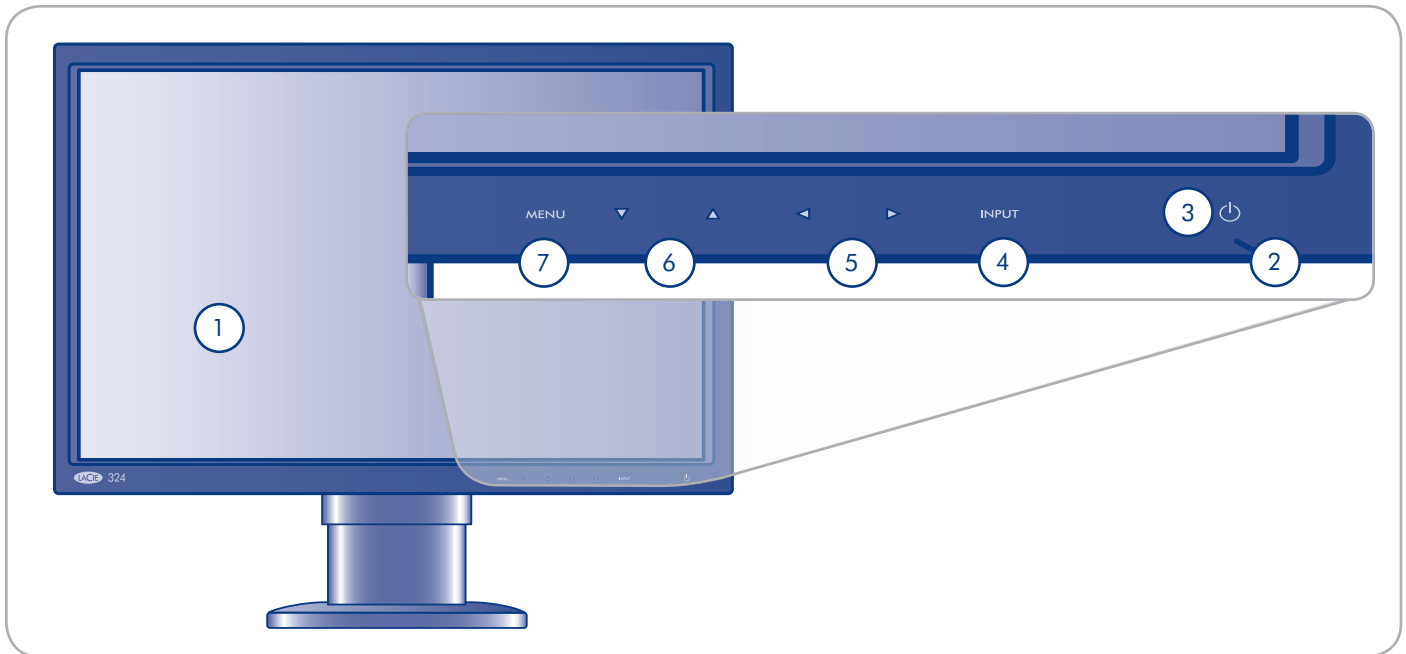

- ① **Display** – Displays images
- ② **Power indicator** – Turns blue when power is turned ON; Turns orange when in IDLE or POWER SAVE mode
- ③ **Power key** – Turns power ON and OFF
- ④ **INPUT key** – When menu is OFF, switches from DVI to VGA to HDMI1/2 video signal source; When menu is ON, used to select menu items
- ⑤ **Left arrow / Right arrow** – When menu screen is ON, used to select menu items
- ⑥ **Up arrow / Down arrow** – When menu screen is ON: used to select menu items
- ⑦ **Menu key** – Displays the on-screen display (OSD) menu

## Rear View

Refer to the diagram below for the names and functions of each component of the monitor.

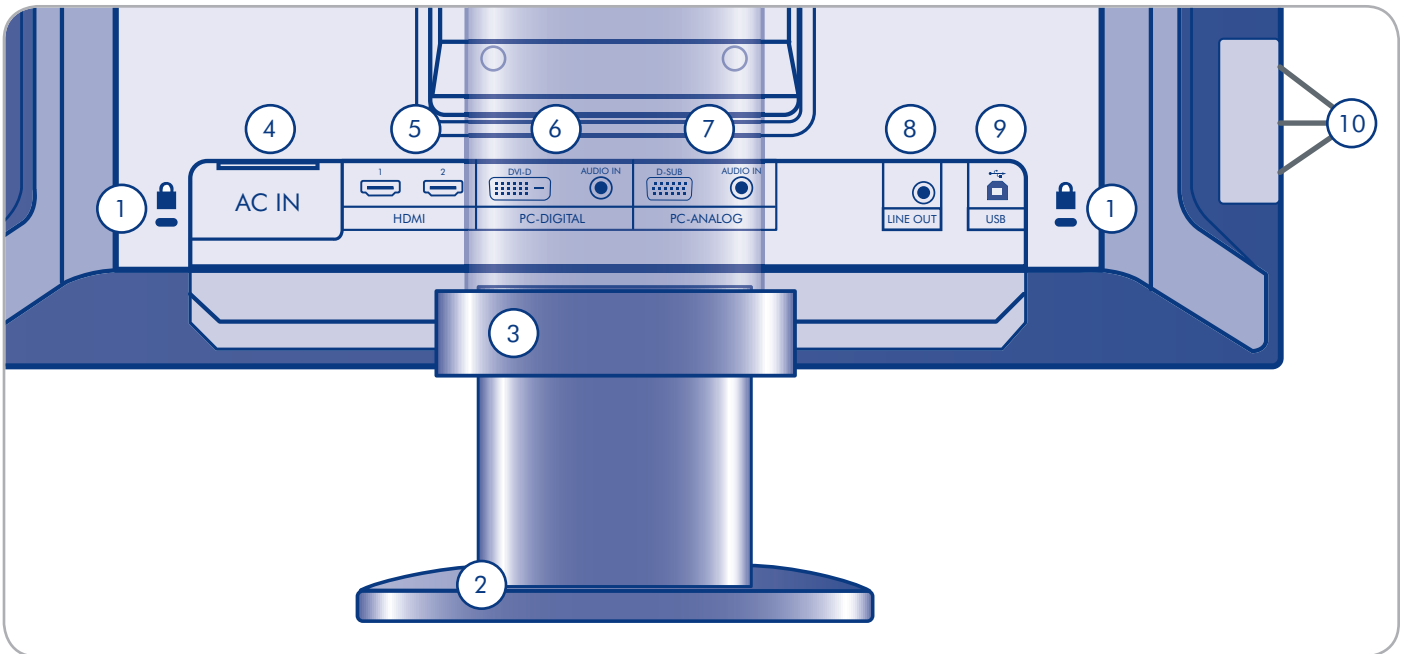

- ① **Theft-prevention slot** – Connects commercial security cables when necessary
- ② **LCD stand base** – The stand base is removable; the 4-screw attachment can be used to attach any alternative VESA-100 standard LCD attachment. See section 2.5. *Installing an Alternative Stand or Attachment.*
- ③ **Cable management accessory** – Used to collect and organize cables. See the **NOTE** in section 2.1. *Connecting the Monitor to Your Computer.*
- ④ **AC-IN connector** – Connects the power cable
- ⑤ **HDMI (1, 2)** – Connects video devices
- ⑥ **PC-Digital** –
  - ◆ **DVI-D** – Connects your computer’s digital (DVI) output connector
  - ◆ **Audio IN** – Connects your computer’s audio output terminal
- ⑦ **PC-Analog** –
  - ◆ **D-SUB** – Connects your computer’s RGB output connector
  - ◆ **Audio IN** – Connects your computer’s audio output terminal.
- ⑧ **Line out** – Connects headphones or speakers
- ⑨ **USB upstream (1 port)** – Connects your computer’s USB connector using USB cable (included).
- ⑩ **USB downstream (3 ports)** – Connects USB-compatible peripherals (mouse, keyboard, etc.).

## 2. Getting Connected

Installing your LaCie 324 LCD Monitor is easy, requiring only a few simple connections:

- ◆ [2.1. Connecting the Monitor to Your Computer](#)
- ◆ [2.2. Connecting Headphones or Speakers](#)
- ◆ [2.3. Connecting USB Devices](#)
- ◆ [2.4. Ergonomic Adjustments](#)
- ◆ [2.5. Installing an Alternative Stand or Attachment](#)

## 2.1. Connecting the Monitor to Your Computer

To attach the LCD monitor to your system, follow these instructions:

1. Power off your computer.
2. Connect the signal cable (see Fig. 2.1-A):

### 2a. For a PC or MAC with DVI digital output:

Connect the DVI signal cable to the DVI connector on your computer. Connect the other end of the DVI cable to the monitor's DVI input. Tighten all screws.

### 2b. For a PC or MAC with Analog output:

Connect a 15-pin mini D-SUB to D-SUB signal cable (not included) to the 15-pin mini D-SUB connector on your computer. Connect the other end of this cable to the monitor's D-SUB (VGA) input.

### 2c. For a video source with HDMI output:

Connect the HDMI signal cable to the HDMI connector on your computer. Connect the other end of this cable to the monitor's HDMI 1 or HDMI 2 input.



**TECHNICAL NOTE:** Up to 4 video sources can be connected to the monitor at the same time using the DVI, VGA, HDMI 1 and HDMI 2 input ports.

3. Connect the included audio cable to the monitor's AUDIO IN port. If you are connecting two computers to the monitor, you can connect two audio cables to the monitor's AUDIO IN ports. Video sources connected through HDMI require no additional audio cable.
4. Connect the other end of the audio cable to the AUDIO OUT terminal on your PC or Mac.



**NOTE:** To keep the cables neatly organized, place them into the cable management accessory that clips into place on the back of the LCD stand (Fig. 2.1-B).

5. Connect one end of the power cord to the AC inlet on the back of the monitor and the other end to a power outlet.
6. Push the power key to turn on the monitor, and turn on your computer.

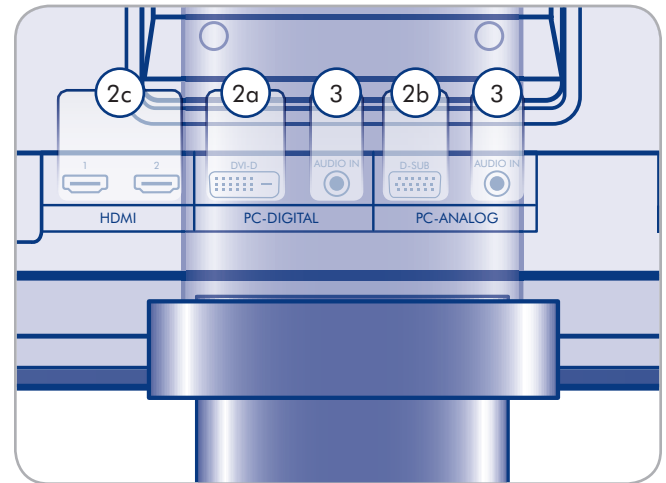

Figure 2.1-A

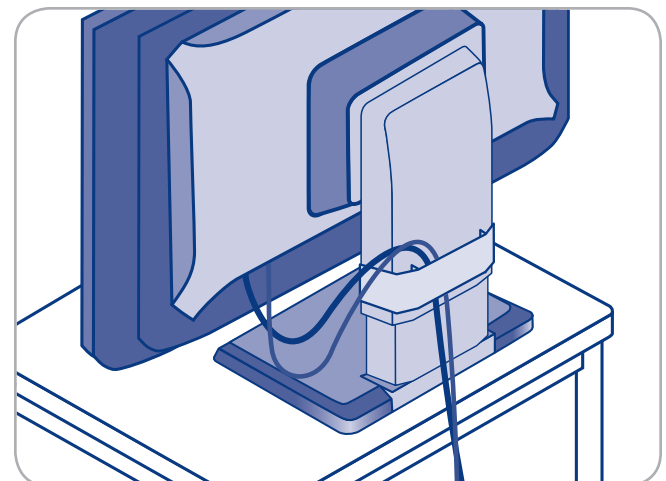

Figure 2.1-B

## 2.2. Connecting Headphones or Speakers

### To connect headphones or speakers:

Simply plug your headphones or speakers into the LINE OUT port located on the rear of the monitor (Fig. 2.2).

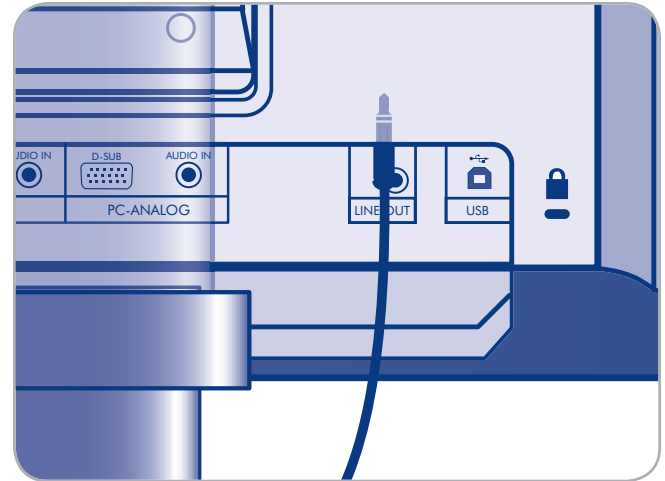

Figure 2.2

## 2.3. Connecting USB Devices

USB devices can be connected to the USB connectors located on the side of the monitor.

### To connect USB Devices:

1. Connect the USB host cable to a USB terminal on your computer and to the USB host port on the monitor (Fig. 2.3). The monitor's USB hub is now connected to your computer.
2. Connect USB peripherals to the USB connectors located on the side of the monitor (Fig. 2.3).

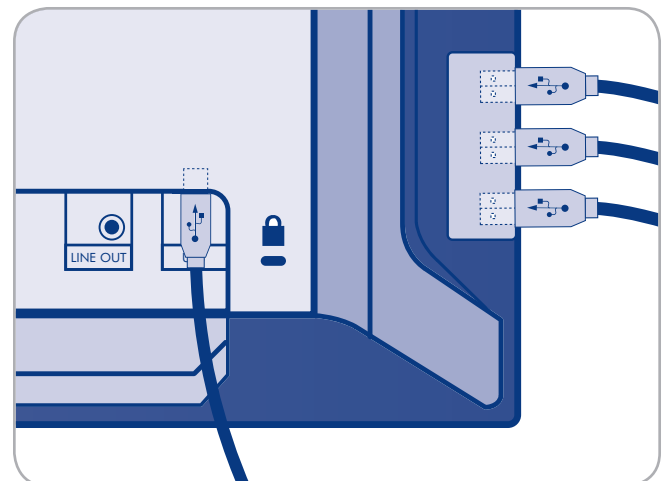

Figure 2.3

## 2.4. Ergonomic Adjustments



**CAUTION:** Use care when raising, lowering, tilting or swiveling the monitor screen.

### 2.4.1. Raise and Lower Monitor Screen

To raise or lower screen, place hands on each side of the monitor and raise or lower to the desired height (Fig. 2.4.1).

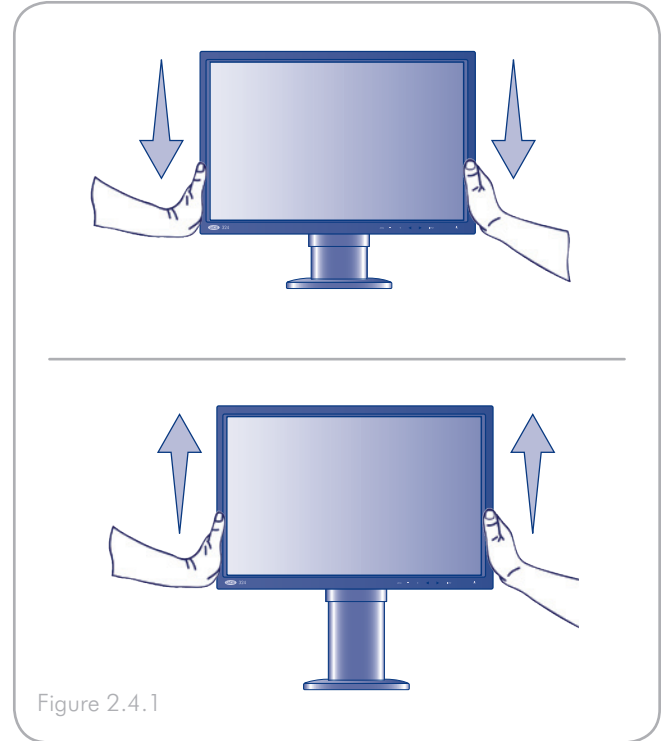

### 2.4.2. Screen Tilt

Grasp the top and bottom sides of the monitor screen with your hands and adjust the tilt as desired (Fig. 2.4.2).

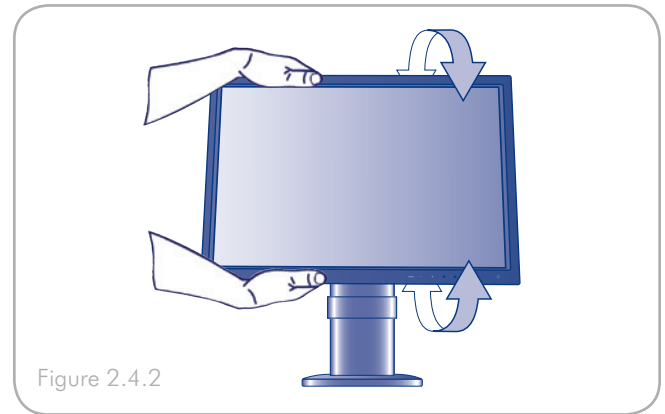

### 2.4.3. Swivel

Grasp both sides of the monitor screen with your hands and adjust the swivel as desired (Fig. 2.4.3).



**NOTE:** The base of the LaCie 324 monitor is designed to swivel on a hard, flat surface. The entire unit turns, not just the display.

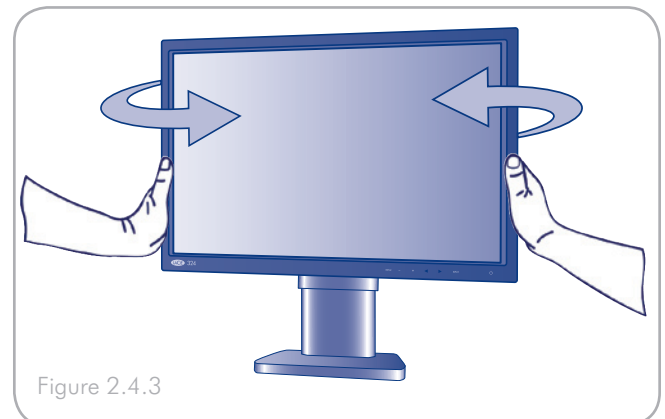



## 2.5. Installing an Alternative Stand or Attachment

The base of the LaCie 324 can be disconnected to attach a flexible monitor arm or other attachment compliant with VESA 100 standards. Prepare the arm and screws required for installation beforehand.

### Remove monitor stand for mounting

To prepare the monitor for alternate mounting purposes:

1. Power off the monitor and your computer.
2. Disconnect all cables including the power cable.
3. Place hands on each side of the monitor and lift up to the highest position.
4. Place monitor face down on a non-abrasive surface. To prevent any scratching or damage, spread a soft cloth underneath the LCD panel during this operation.
5. Remove the 2 mounting screws accessible through the holes in the stand (Fig. 2.5-A).
6. Slide out and remove both parts of the VESA cover from the stand (Fig. 2.5-A).
7. Place one hand around the base and remove the remaining 2 mounting screws (Fig. 2.5-B).

The monitor can now be mounted using an alternative attachment. If the stand needs to be re-attached, simply reverse this process.

### Attaching the alternative stand or attachment

Attach the stand or arm attachment using the 4 screws from the stand removal.



#### IMPORTANT INFO:

- ◆ For safety reasons, please make sure that the monitor arm can stably support the weight of this monitor (approx. 8.3 kg/18.3 lb.).
- ◆ To avoid damage to the monitor and stand when mounting, please use only M4x10 screws such as those included with the monitor.
- ◆ Refer to the alternative stand's documentation for instructions specific to that attachment.

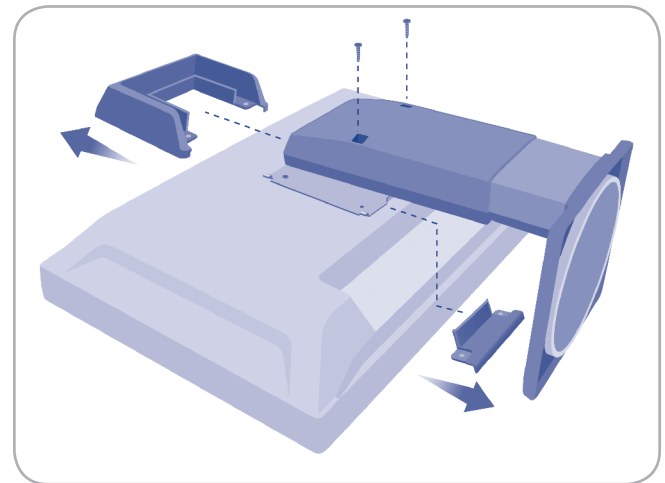

Figure 2.5-A

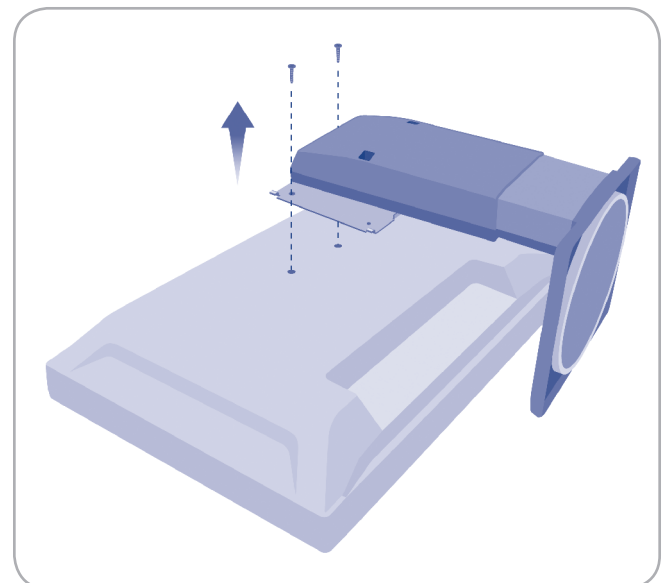

Figure 2.5-B

## 3. Monitor Operation

Refer to the following sections for information on viewing video on your LaCie 324 LCD Monitor:

- ◆ *3.1. About Zoom Modes and Aspect Ratio*
  - ◆ *3.2. Using the Picture-in-Picture Function*
    - ◇ *3.2.1. Turning PiP ON/OFF*
    - ◇ *3.2.2. Adjusting the Position of the PiP*
    - ◇ *3.2.3. Modifying PiP Size*
    - ◇ *3.2.4. Switching Audio Output to Speakers*
    - ◇ *3.2.5. Switching Input Source Displayed on the PiP*
-

### 3.1. About Zoom Modes and Aspect Ratio

Aspect Ratio refers to the ratio of the vertical length to horizontal length (number of pixels) of the display or image.

The LaCie 324 supports the following aspect ratios:

- ◆ 16:9
- ◆ 16:10
- ◆ 4:3

Virtually all video sources available today use one of these three aspect ratios. 16:10 is the native format of the LaCie 324 LCD Monitor, corresponding to a 1920 x 1200 resolution computer video signal. When using a 4:3 or 16:9 video source, such as an HD Video source or a 1600 x 1200 computer video signal, the monitor can apply a zoom transformation to adjust the signal to the monitor.



**NOTE:** Refer to the user manuals of your devices for the aspect ratios of their input sources.



**NOTE:** Refer to the On-Screen Manual for PC-Analog and PC-Digital input aspect ratios.

The four zoom modes are Real, SmartZoom, Zoom and Dx2D and they have the following behavior:

Mode	Aspect Ratio	4:3 Video	16:9 Video
REAL	Applies no modification and displays real input signal resolution in the center of the display		
Smart Zoom	Maintains the aspect ratio of the source and upscales it to 1600 x 1200 or 1920 x 1080		
Zoom	Upscales the source to 1920 x 1080, maximizing its size; some distortion may occur because aspect ratio is not respected		
Dx2D	Extends both sides of panorama display to magnify to 1920 x 1200		

## 3.2. Using the Picture-in-Picture (PiP) Function

A secondary video source can be displayed while a computer display source is active on the main display. The following explains how to use the on-screen menu to operate this function.

To access the Picture-in-Picture menu, press MENU, select "PiP" with the INPUT key and the PiP Settings screen appears.

---

### 3.2.1. Turning PiP On/Off

Toggle the PiP function ON/OFF on the PiP Settings screen by pressing the Left/Right arrows on the front panel of the Monitor.

---

### 3.2.2. Adjusting the Position of the PiP

The position of the Sub-Display can be adjusted by doing the following : When the PiP function is ON, toggle the PiP Position function by using the Left/Right arrows on the front panel of the Monitor. The PiP position changes each time either arrow is pressed in the following order : Upper right - Lower right - Lower left - Upper left - Upper right.

---

### 3.2.3. Modifying the PiP Size

When the Sub-Display is ON, toggle the PiP Size function by using the Left/Right arrows on the front panel of the Monitor. The PiP size changes each time either arrow is pressed in the following order : Small - Medium - Large - Small.

The dimensions of the Picture-in-Picture depend on the original video source aspect ratio PiP Size mode applied. For your reference, they can be found in the following table:

Aspect Ratio of Source	Large	Medium	Small
4:3	800 x 600	640 x 480	480 x 360
5:4	800 x 600	640 x 480	480 x 360
16:9	800 x 450	640 x 360	480 x 270
16:10	800 x 450	640 x 360	480 x 270

### 3.2.4. Switching Audio Output to Speakers

When you toggle the PiP Audio Select function , the audio output to headphone/speakers port switches from PiP audio to main display audio and vice versa.

---

### 3.2.5. Switching Input Source Displayed on the PiP

Toggle the PiP Input Select function. The input source displayed on the Sub-Display changes in the following order : PC-Digital - HDMI-1 - HDMI-2 - PC- Analog

The configurations in which the PiP is operable with the LaCie 324 are summarized in the following table:

Main Display	PiP
PC-Digital	PC-Analog, HDMI-1, HDMI-2
PC-Analog	PC-Digital, HDMI-1, HDMI-2

## 4. Settings and Adjustments

Refer to the following sections for information on making settings and adjustments to your LaCie 324 LCD Monitor:

- ◆ [4.1. Settings and Adjustments \(Basic Operations\)](#)
- ◆ [4.2. Advanced Settings](#)
  - ◇ [4.2.1. Picture-in-Picture Settings](#)
  - ◇ [4.2.2. DVI/VGA Settings](#)
  - ◇ [4.2.3. HDMI Settings](#)
  - ◇ [4.2.4. Other Settings](#)

## 4.1. Settings and Adjustments (Basic Operation)

A variety of adjustments and settings can be performed using the Settings / Adjust Menu (herein referred to as “menu”) displayed on the screen.

To enter the Settings / Adjust Menu, press the MENU key. To exit this menu, press the INPUT key.

Adjustments and settings can be made using the following keys located on the front of the monitor:

Key Name	Functions
menu	<ul style="list-style-type: none"> <li>◆ Displays the menu</li> <li>◆ Selects the RETURN function</li> <li>◆ Will lock the menu when held for approximately 3 seconds to lock/unlock the menu. (When menu is off)</li> </ul>
Up and Down arrows	When menu screen is ON: used to navigate in the menu items
Left and Right arrows	When menu screen is ON: used to navigate in the menu items
INPUT	When menu screen is ON: used to select menu items
	When menu is OFF: toggles between PC-Digital, PC-Analog, HDMI1 and HDMI2 inputs
	Adjusts automatically when held down for a long period of time (during PC-Analog input)

## 4.2. Advanced Settings

### 4.2.1. Picture-in-Picture (PiP) Settings



**NOTE:** This menu is not visible when the main display source is HDMI.

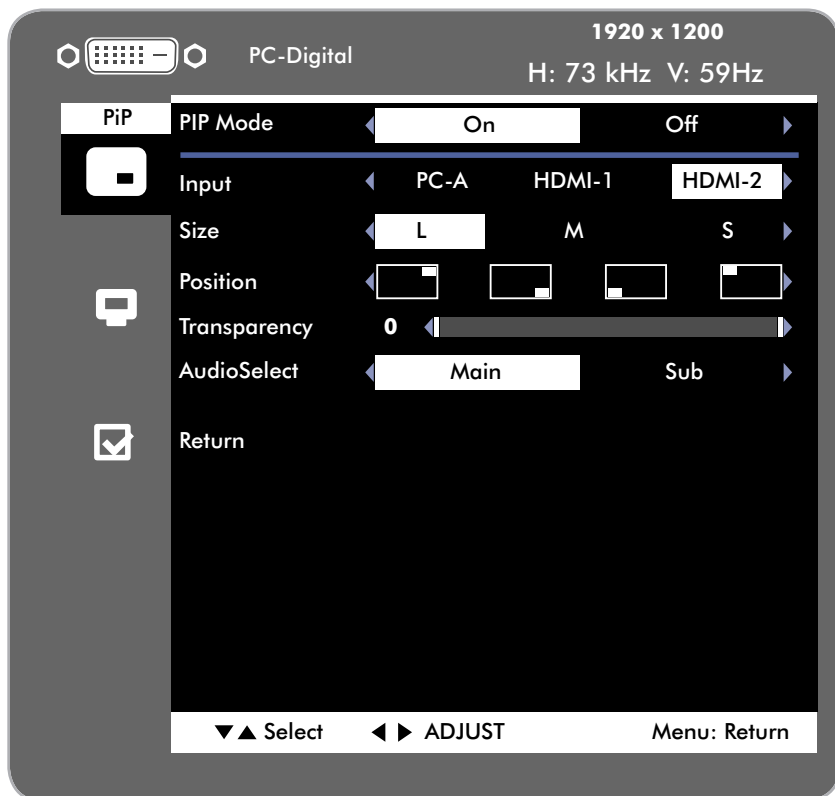

Item	Description
PiP Mode	Turns PiP ON/OFF (Turn ON to view the PiP)
Source*	Selects PiP input source – PC-Digital, PC-Analog, HDMI-1, HDMI-2
Size*	Toggles PiP size
Position*	Designates PiP position
Transparency*	Sets degree of PiP transparency
Output Audio*	Toggles audio source between PiP source and main display source
Return	Returns to the main menu

\*Not shown when the PiP is OFF



### 4.2.2. DVI/VGA Settings



**NOTE:** The contents of the video settings menu depend on which video input is active.

Item	Description
Screen mode	This function toggles between six preset display modes called Standard, Cinema, CG, Photo, Text and DTP. Each of these modes optimizes image quality for specific uses by adjusting Luminance, Brightness, Contrast, Tint, Saturation, Sharpness. Please find below the default settings corresponding to these modes. These settings can be changed. The Cinema mode is best for viewing video content. The CG mode is best in the context of animation or gaming applications.
ECO	The ECO mode reduces power consumption.
Brightness	Adjusts screen brightness
Contrast	Adjusts screen contrast
Color Temperature	Toggles between five preset color temperatures. The first four are 5000K (yellowish), 6500K (neutral), 7200K, 9300K (blueish). The last is a user mode where color temperature can be adjusted manually.
Gamma	Adjusts gamma to standard values
Aspect Ratio	Toggles between Real, Smart Zoom, Zoom, Dx2D (Panorama) zoom modes. Refer to the "About Zoom Modes and Aspect Ratio" section on page X
Over Speed	This function toggles the Over Speed Mode ON and OFF. When Over Speed Mode is ON, the display's refresh rate is accelerated by limiting its image processing functions.
Return	Returns to the Main Menu

### 4.2.3. HDMI Video Settings

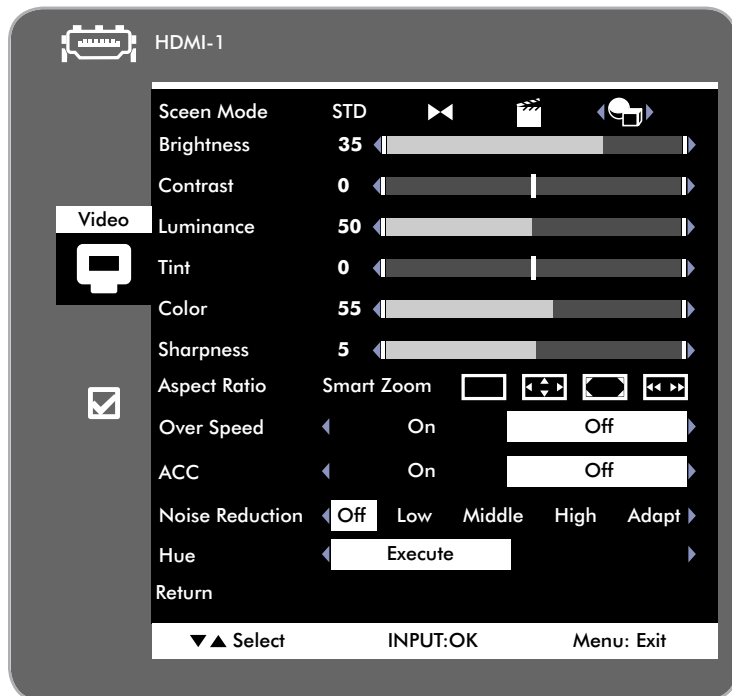

Item	Description
Screen mode	This function toggles between three preset display modes called Standard, Cinema, CG, Photo, Text and DTP. Each of these modes optimizes image quality for specific uses by adjusting Luminance, Brightness, Contrast, Tint, Saturation, Sharpness. Please find below the default settings corresponding to these modes. These settings can be changed. The Cinema mode is best for viewing video content. The CG mode is best in the context of animation or gaming applications.
Brightness	Adjusts screen Brightness
Contrast	Adjusts screen contrast
Luminance	Adjusts the Brightness of the screen
Tint	Adjusts redness of colors on the screen.
Color	Adjusts density of colors on the screen.
Aspect Ratio	Toggles between Real, Smart Zoom, Zoom, Dx2D (Panorama) zoom modes. Refer to section <a href="#">3.1. About Zoom Modes and Aspect Ratio</a>
Over Speed Mode	This function toggles the Over Speed mode ON and OFF. When Over Speed mode is ON, the display's refresh rate is accelerated by limiting its image processing functions.
ACC	The Adaptive Contrast Control function automatically adjusts contrast to prevent loss of detail when viewing extremely dark or extremely bright scenes.
Noise Reduction	Enabling the noise reduction function will limit screen noise and contour fuzziness.

Hue	This function allows you to independently adjust the chromaticity of the 6 Primary colors: red, green, blue, cyan, magenta, yellow.	
Red	Adjusts red Left: moves the chromaticity of Red towards magenta Right: moves the chromaticity of Red towards yellow	
Yellow	Adjusts yellow Left: moves the chromaticity of Yellow towards red Right: moves the chromaticity of Yellow towards green	
Green	Adjusts green Left: moves the chromaticity of Green towards yellow Right: moves the chromaticity of Green towards cyan	
Cyan	Adjusts cyan Left: moves the chromaticity of Cyan towards green Right: moves the chromaticity of Cyan towards blue	
Blue	Adjusts blue Left: moves the chromaticity of Blue towards cyan Right: moves the chromaticity of Blue towards magenta	
Magenta	Adjusts magenta Left: moves the chromaticity of Magenta towards blue Right: moves the chromaticity of Magenta towards red	
Return	Returns to the Main Menu	

### Screen Mode Presets

	Standard	Cinema	CG	Photo	Text	DTP
Brightness	35	35	35	35	35	35
Contrast	0	-10	0	0	0	-100
Color Temperature	6500	6500	7200	6500	7200	5000
Gamma	2.2	2.2	1.8	2.2	2.2	1.8

### 4.2.4. Other Settings

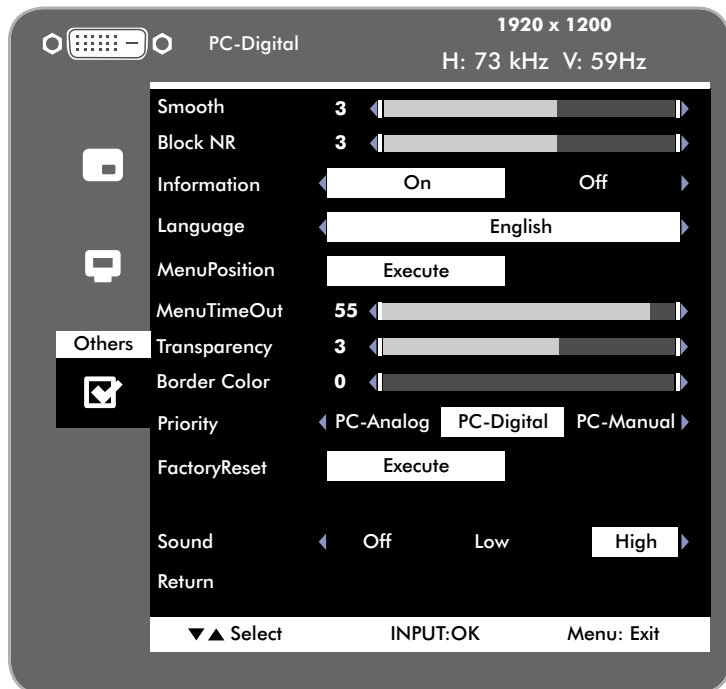

Item	Description
Smooth	Adjusts the sharpness of the monitor image
Block NR	Reduces block noise generated when playing MPEG or other compressed movie formats
Information	Sets ON/OFF for display When set to ON, input source name and input signal information is displayed at all times
Language	Sets menu screen language to English, French, Italian, German or Spanish
MenuPosition	Specifies the position of the menu on the screen
MenuTimeOut	Sets menu display time
Transparency	Sets the degree of background transparency of the menu screen
Border Color	This function adjusts from black to white the color of the areas of the screen surrounding the video content
Priority	Sets the type of input signal used when more than one input is connected
FactoryReset	Returns all setting values to factory default settings <b>NOTE:</b> The Language setting is not reset.
Sound	Toggles volume of monitor key sounds.
Return	Returns to the main menu

## 5. Troubleshooting

If your LaCie 324 Monitor is not working correctly, please refer to the following checklist to determine the source of the problem. If you have gone through all of the points on the checklist and your monitor still does not work properly, please check the FAQs that are regularly published on our website – [www.lacie.com](http://www.lacie.com).

One of these FAQs may provide an answer to your specific question. If you need further assistance, please contact your LaCie reseller or LaCie Customer Support (see section 6. [Contacting Customer Support](#) for details).

### Manual Updates

LaCie strives to give you the most up-to-date, comprehensive user manuals available on the market. It is our goal to provide you with a friendly, easy-to-use format that will help you quickly install and utilize the many functions of your new device.

If your user manual does not reflect the configuration of the product you purchased, please check our web site for the most current version of the user manual.

[www.lacie.com](http://www.lacie.com)

Problem	Solution
No picture	<ul style="list-style-type: none"> <li>◆ The signal cable should be completely connected to the display card/computer.</li> <li>◆ The display card should be completely seated in its slot.</li> <li>◆ Front power button and computer power switch should be in the ON position.</li> <li>◆ Check to make sure that the resolution selected in the operating system is supported by the monitor (please consult display card or system manual to change graphics mode).</li> <li>◆ Check the monitor and your display card with respect to compatibility and recommended settings.</li> <li>◆ Check the signal cable connector for bent or pushed-in pins.</li> <li>◆ Verify that you have selected the right video input port (you can cycle through the video ports by hitting the INPUT key on the front panel of your monitor).</li> </ul>
Power key does not respond	Unplug the monitor power cord from the AC outlet to turn off and reset the monitor.
LED on monitor is not lit	Power button should be in the ON position and power cord should be connected.
Image Persistence	<p>Please be aware that LCD monitors may experience a phenomenon known as “image persistence.” Image persistence occurs when a residual or “ghost” image of a previous image remains visible on the screen. Unlike CRT monitors, LCD monitors’ image persistence is not permanent, but constant images being displayed for a long period of time should be avoided. To alleviate image persistence, turn off the monitor for as long as the previous image was displayed. For example, if an image was on the monitor for one hour and a residual image remains, the monitor should be turned off for one hour to erase the image.</p> <hr/> <p><b>NOTE:</b> As with all personal display devices, LaCie recommends displaying moving images and using a moving screen saver at regular intervals whenever the screen is idle or turning off the monitor when not in use.</p> <hr/>
OSD warning OUT OF RANGE is displayed and image is displayed only roughly (pixels are missing)	Either signal clock or resolution is too high. Choose one of the supported modes.

Problem	Solution
OSD warning OUT OF RANGE or INPUT NOT SUPPORTED is displayed on a blank screen	Signal frequency is out of range. Choose one of the supported modes.
Image is unstable or unfocused	<ul style="list-style-type: none"><li>◆ Signal cable should be completely attached to the computer.</li><li>◆ Use the OSD Image Adjust controls to focus and adjust display by increasing or decreasing the Fine total. When the display mode is changed, the OSD Image Adjust settings may need to be readjusted.</li><li>◆ Make sure your video card is compatible with recommended signal timings of the monitor.</li><li>◆ If your text is garbled, change the video mode to non-interlaced and use 60Hz refresh rate.</li></ul>
Display image is not sized properly	Use the OSD Video Settings or HDMI Settings / Aspect Ratio control to adjust the image size. Make sure your display video card and system are compatible with the selected mode of the monitor (please consult display video card or system manual to change graphics mode.)
No signal	Make certain the computer is not in a power-saving mode (touch the keyboard or mouse). If video does not return to the screen, turn the power off and on again.
No sound coming out of the headphones or speakers	<ul style="list-style-type: none"><li>◆ Verify that your headphone or speaker cable is properly plugged into the audio out port</li><li>◆ If your audio is coming from your computer verify that the computer-to-monitor audio cable is properly plugged into your computer sound card (green connector) as well as the monitor's line in audio port located next to the video signal input port you are using.</li><li>◆ The volume may be too low. Verify in your operating system's sound options that volume is not too low.</li><li>◆ The audio output may be muted. Verify in your operating system's sound options that the sound has not been muted.</li></ul>

## 6. Contacting Customer Support

### Before You Contact Technical Support

Read the User Manual and review the Troubleshooting section. If you have asked yourself all of the pertinent questions in the troubleshooting checklist, and you still can't get your LaCie monitor to work properly, contact us via the contacts on the next page. Before contacting us, make sure that you are in front of your computer and that you have the following information on hand:

Information	Where to Find Information
LaCie 324 Monitor serial number	Located on a sticker at the back of monitor.
Macintosh/PC model	<b>Mac users:</b> Click on the Apple icon in the menu bar and select <b>About This Mac</b> . <b>Windows users:</b> Right click <b>My Computer</b> and select <b>Properties &gt; General</b> .
Operating system version	
Processor speed	
Computer memory	<b>Mac users:</b> Click on the Apple icon in the finder bar and select <b>About this Mac</b> . Select <b>More Info...</b> The Apple System Profiler will launch and will list your internal and external peripherals. <b>Windows users:</b> Right click <b>My Computer</b> and select <b>Properties &gt; Hardware</b> .
The brand and model of the graphics board used in your computer	

## LaCie Customer Support Contacts

LaCie Asia, Singapore, and Hong Kong Contact us at: <a href="http://www.lacie.com/asia/contact/">http://www.lacie.com/asia/contact/</a>	LaCie Australia Contact us at: <a href="http://www.lacie.com/au/contact/">http://www.lacie.com/au/contact/</a>
LaCie Belgium Contact us at: <a href="http://www.lacie.com/be/contact/">http://www.lacie.com/be/contact/</a> (Français)	LaCie Canada Contact us at: <a href="http://www.lacie.com/caen/contact/">http://www.lacie.com/caen/contact/</a> (English)
LaCie Denmark Contact us at: <a href="http://www.lacie.com/dk/contact">http://www.lacie.com/dk/contact</a>	LaCie Finland Contact us at: <a href="http://www.lacie.com/fi/contact/">http://www.lacie.com/fi/contact/</a>
LaCie France Contact us at: <a href="http://www.lacie.com/fr/contact/">http://www.lacie.com/fr/contact/</a>	LaCie Germany Contact us at: <a href="http://www.lacie.com/de/contact/">http://www.lacie.com/de/contact/</a>
LaCie Italy Contact us at: <a href="http://www.lacie.com/it/contact/">http://www.lacie.com/it/contact/</a>	LaCie Japan Contact us at: <a href="http://www.lacie.com/jp/contact/">http://www.lacie.com/jp/contact/</a>
LaCie Netherlands Contact us at: <a href="http://www.lacie.com/nl/contact/">http://www.lacie.com/nl/contact/</a>	LaCie Norway Contact us at: <a href="http://www.lacie.com/no/contact/">http://www.lacie.com/no/contact/</a>
LaCie Spain Contact us at: <a href="http://www.lacie.com/es/contact/">http://www.lacie.com/es/contact/</a>	LaCie Sweden Contact us at: <a href="http://www.lacie.com/se/contact">http://www.lacie.com/se/contact</a>
LaCie Switzerland Contact us at: <a href="http://www.lacie.com/chfr/contact/">http://www.lacie.com/chfr/contact/</a> (Français)	LaCie United Kingdom Contact us at: <a href="http://www.lacie.com/uk/contact">http://www.lacie.com/uk/contact</a>
LaCie Ireland Contact us at: <a href="http://www.lacie.com/ie/contact/">http://www.lacie.com/ie/contact/</a>	LaCie USA Contact us at: <a href="http://www.lacie.com/contact/">http://www.lacie.com/contact/</a>
LaCie International Contact us at: <a href="http://www.lacie.com/intl/contact/">http://www.lacie.com/intl/contact/</a>	



## 7. Warranty Information

LaCie warrants your monitor against any defect in material and workmanship, under normal use, for the period designated on your warranty certificate. In the event this product is found to be defective within the warranty period, LaCie will, at its option, repair or replace the defective product. This warranty is void if:

- ◆ The monitor was operated/stored in abnormal use or maintenance conditions;
- ◆ The monitor is repaired, modified or altered, unless such repair, modification or alteration is expressly authorized in writing by LaCie;
- ◆ The monitor was subjected to abuse, neglect, lightning strike, electrical fault, improper packaging or accident;
- ◆ The monitor was installed improperly;
- ◆ The serial number of the monitor is defaced or missing;
- ◆ The broken part is a replacement part such as a pickup tray, etc.
- ◆ The tamper seal on the monitor casing is broken.

LaCie will not, under any circumstances, be liable for direct, special or consequential damages such as, but not limited to, damage or loss of property or equipment, loss of profits or revenues, cost of replacement goods, or expense or inconvenience caused by service interruptions.

Under no circumstances will any person be entitled to any sum greater than the purchase price paid for the monitor.

To obtain warranty service, call LaCie Technical Support. You will be asked to provide your LaCie product's serial number, and you may be asked to furnish proof of purchase to confirm that the monitor is still under warranty.

All monitors returned to LaCie must be securely packaged in their original box and shipped with postage prepaid.

---

**IMPORTANT INFO:** Register online for free technical support: [www.lacie.com/register](http://www.lacie.com/register)

---